

Cadillac[®] Vortex Meter

Central Station Steam Co.[®]

GENERAL INFORMATION

CV-P Series

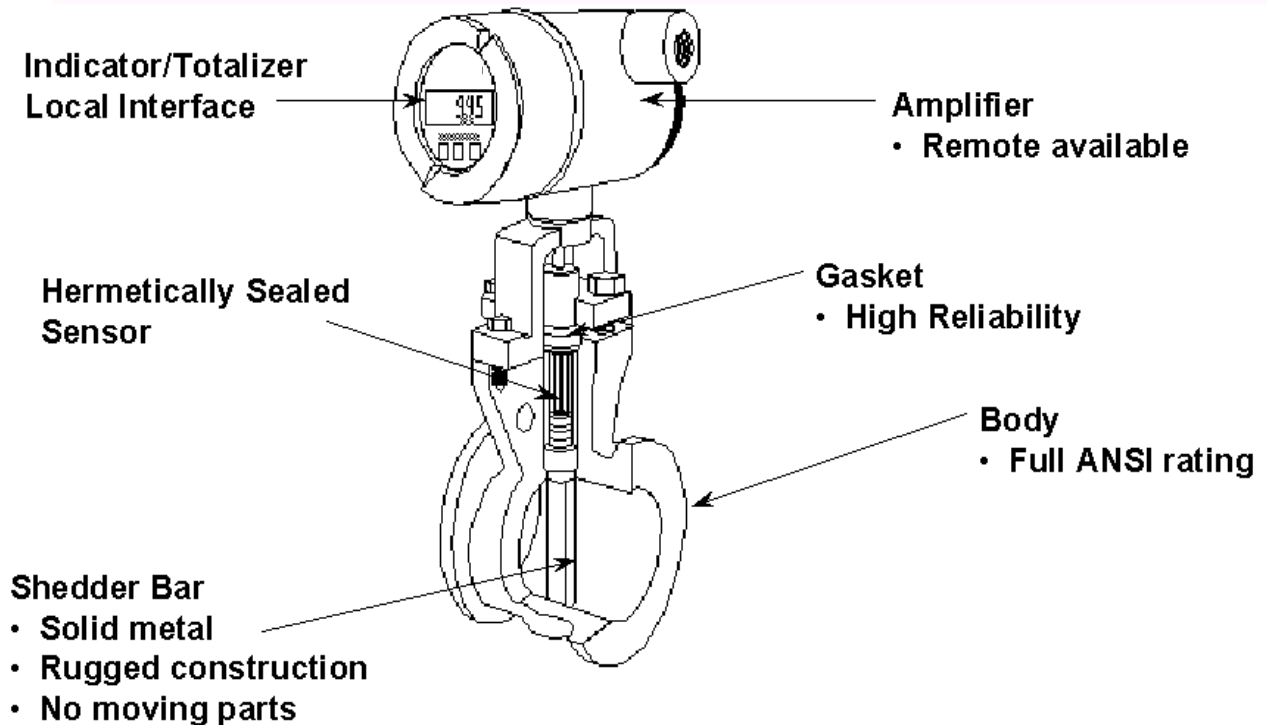

Central Station Steam Co.[®]

CADILLAC[®] METERS

15615 SW 74th Ave, #150
Tigard, OR 97224

www.cadillacmeter.com

Phone: 888-556-3913

Fax: 503-624-6131

THE STEAM METER OF CHOICE

The Cadillac® Vortex Meter is a rate and totalizing meter which is capable of measuring liquid, steam and gas. Due to its rugged design it is particularly suitable for direct steam measurement. In any steam system the Cadillac® Vortex Meter is the number one technology choice due to Cadillac®'s accuracy, linearity, reliability and rangeability.

Like many other flow meters, the Cadillac® Vortex Meter is a velocity measuring device which computes flow by multiplying the effective cross sectional area of the flow meter with the detected fluid velocity. The meter has no moving parts and consists of a meter & bluff body (shedder bar) and amplifier assembly. It detects velocity by measuring the frequency of the vortices, as they peel off the shedder bar of the flowmeter. The frequency of these "Karman" vortices is directly proportional to the velocity of the moving fluid, whether this is a gas or liquid.

THE NEW INDUSTRY STANDARD

Since the late 1970's, the Vortex direct steam flow meters have been acknowledged as the industry standard. Customers choose the Cadillac® Vortex Meter because of proven:

◇ **ACCURACY, DEPENDABILITY, CONSISTENCY, LOW MAINTENANCE, RANGEABILITY**

APPLICATIONS

- Data Source for energy management system, DCS, district-wide systems.
- Energy-Customer Billing from accurately totalized flow measurements.
- Basis for internal cost distribution using campus-wide systems.
- Process monitoring from central control rooms.
- Direct Steam measurements at both Boiler and point of use locations.

FEATURES

- **ACCURACY:** +/- 0.6% of reading for liquids. +/-1.0% of the reading for gas and steam.
- **RANGEABILITY.:** Typically 15 to 1 turndown or up to 30 to 1 when sized for "Best Fit".
With seasonal steam load variation, the need for a large turndown is essential. Cadillac® Vortex Meters will accurately measure all load requirements with proper sizing.
- **LONGEVITY:** Mean time between failure (MTBF) of 50 years.
With no moving parts and through simple robust design the MTBF of the shedder bar is 50 years. With proper system maintenance Cadillac® Vortex Meters will provide reliable, accurate service beyond all flow technologies.
- **MODERN ELECTRONICS:** meeting the challenges of the next millennium
Meters are equipped with electronics capable of registering locally, remotely or interfacing with an energy management system. Built to withstand the toughest conditions.

PRINCIPLE OF OPERATION

The "Karman" vortex meter principle is clearly illustrated by a flag waving in the wind. As the air passes across the flag pole, vortices peel off and the flag is shaped by these pressure area's. You will notice that, at low wind velocity, the flag will move slowly from side to side. As the wind increases, the flag will start to flutter, representing the increased frequency and intensity of these flag pole generated vortices as they pass

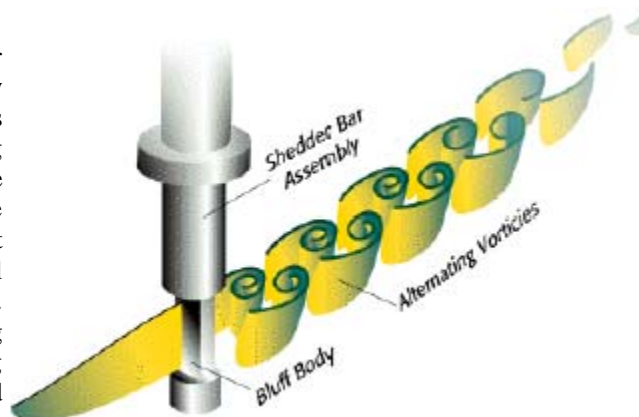

by. Wind velocity can thus be determined by measuring the frequency of that flutter.

The shedder bar of the Cadillac® Vortex Meter is a solid piece of metal machined into a shape to maximize the strength of the vortex. As this vortex peels off, it temporarily causes a low-pressure area on one side, which puts sideways stress on the shedder bar. This stress is detected by embedded pressure sensitive piezoelectric crystals, which produce a voltage spike when compressed. By detecting and counting the frequency of these

(Continued on page 3)

(Continued from page 2)

spikes, we can establish fluid velocity. Each vortex meter is tested to determine the relationship between velocity/flow rate and vortex frequency, which results in a meter K-factor expressed in "Pulses/Gallon". This volumetric relationship can then be converted to other engineering units and the flow meter converter can then retransmit this information with a 4-20 mA current signal or conditioned pulse. An optional LCD Indicator/Totalizer can display and totalize in whatever engineering units you prefer. For compressible mediums, such as gases and steam, the meter amplifier can correct for temperature and pressure with the MASS option, which includes a temperature element in shedder bar and look up tables for ideal gases and steam. For mediums other than saturated steam an external pressure source must be provided as shown in the drawing below. Outputs from the meter with the MASS option are compensated and linear for the compressible medium being measured.

METER INSTALLATION

To ensure proper operation, all Cadillac® Steam flowmeters should be installed with proper flow conditioning. This requires certain minimum upstream and downstream straight piping runs.

In many steam systems the meter body size will be reduced for optimum meter performance and rangeability. This requires a reducing spool piece as illustrated.

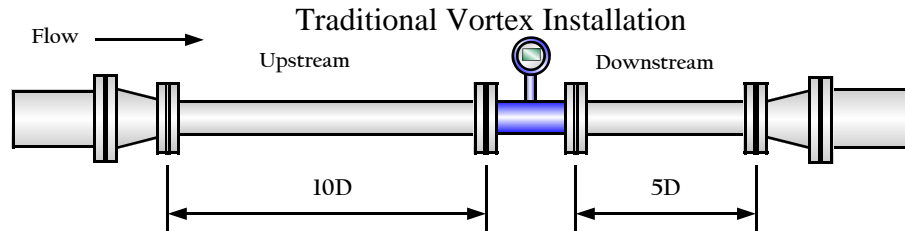

D = nominal Vortex meter diameter

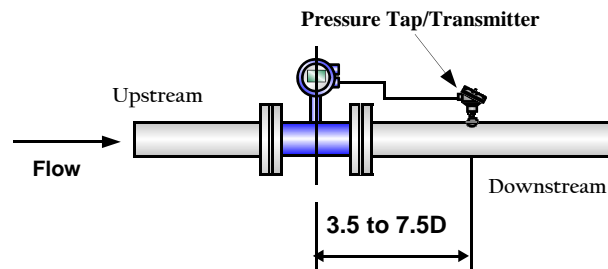

With either reducer or expander piping ensure the upstream pipe length to be 10 nominal pipe diameters or more, and downstream straight pipe to be 5 nominal pipe diameters or more.

METER SIZING INFORMATION

The low-end performance of the meter is a function of the fluid's ability to generate a vortex of significant enough force to be reliably detected. This is dependent on fluid velocity, density and Reynolds number. The high end of the flow meter is also Reynolds number limited, which ultimately impacts the linearity of the relationship between velocity and frequency. In most cases, this represents 250 ft/sec for gases and 33 ft/sec for liquids. To guarantee satisfactory performance, we will check every vortex meter application for suitability and will require process medium, pressure, temperature and expected minimum and maximum flow rates. For easy reference, we are providing you with a table (see below) for saturated steam (at various pressures), water and condensate. If the meter is installed in a high vibration area, the sensitivity of the electronics needs to be turned down and the ability, of measuring low flows reliably, may be compromised. The tables list the minimum and maximum flow capability, between which a flow measurement can be made at stated accuracy. Outside those limits, the accuracy will deteriorate somewhat, the extent of which will depend on the quality of the installation.

Saturated Steam Flow Range Table. (Steam Flow in lbs/hr)							Water/Condensate Range Table.		
Meter Size	5 PSIG	10 PSIG	20 PSIG	50 PSIG	100 PSIG	150 PSIG	Meter Size	Water (GPM)	Condensate (lbs/hr)
0.5"	13-85	14-105	17-140	23-255	30-435	35-615	0.5"	1.7-27	800-12800
1"	30-260	35-325	40-440	55-790	70-1355	80-1915	1"	3.5-82	1730-39640
1.5"	60-625	65-765	80-1050	105-1885	135-3235	165-4565	1.5"	7-196	3540-94600
2"	100-1020	110-1265	130-1740	175-3120	230-5360	270-7565	2"	12-325	5875-156720
3"	190-1980	215-2450	250-3355	335-6025	440-10345	520-14600	3"	24-627	11330-302550
4"	335-3450	370-4260	435-5860	580-10500	765-18050	905-25490	4"	41-1095	19775-528065
6"	730-7550	810-9330	950-12830	1275-23000	1670-39540	2095-55810	6"	80-2400	
8"	1565-13500	1740-16880	2040-22940	2730-41160	3580-70700	4255-99790	8"	187-4290	
10"	2825-21000	3140-25800	3680-35470	4930-63650	6460-109300	7675-154300	10"	330-6630	
12"	4050-30000	4500-37000	5270-50800	7060-91150	9250-156550	10990-221000	12"	475-9500	

CADILLAC® VORTEX METER

Phone: 888-556-3913
or
e-mail: Cadillacmeter@aol.com
for
Engineering Support

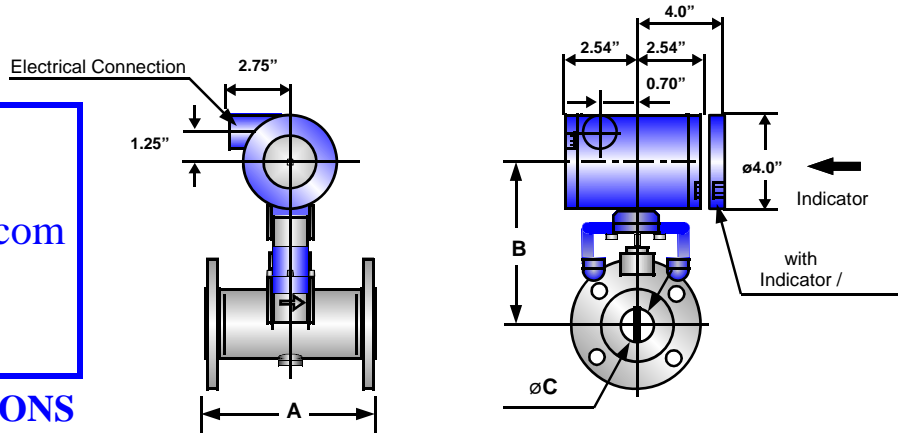

FLANGED METER DIMENSIONS

Meter Size	0.5"	1.0"	1.5"	2.0"	3.0"	4.0"	6.0"	8.0"	10.0"	12.0"	16.0"
"A" (face to face)	5.12"	5.91"	5.91"	6.69"	7.87"	8.66"	10.63"	12.20"	14.57"	15.75"	TBA
"B" (center to center)	7.52"	7.60"	7.87"	8.74"	9.41"	10.00"	10.75"	12.00"	13.43"	14.61"	TBA
"C" (meter ID)	0.50"	1.00"	1.50"	2.00"	3/00"	4.00"	6.00"	8.00"	10.00"	12.00"	16.00"
Weight ANSI Class 150lb	10 lbs	15 lbs	19 lbs	27 lbs	45 lbs	61lbs	81lbs	125 lbs	200 lbs	310 lbs	TBA
Weight ANSI Class 300lb	10 lbs	17 lbs	21 lbs	30 lbs	53 lbs	80 lbs	121lbs	180 lbs	275 lbs	395 lbs	TBA

CADILLAC® VORTEX METER GENERAL SPECIFICATIONS

- Meter will consist of a full-bore body, vortex shedding bar and remote or integral electronics.
- Meter available with local or remote indication or blind housings.
- Meter available with pulse and analog (4-20 mA) outputs.
- Meter will have typical turndown of 15 to 1, or up to 30 to 1 if sized for "Best Fit".
- Meter will have an accuracy of $\pm 1.0\%$ of reading across entire operating range.
- Meter will provide instantaneous and totalized flow available at local indicator or remotely through outputs.
- Meter measures flow using the Karman vortex shedding principle.
- Vortices induce pulses generated from two piezoelectric crystals hermetically sealed & imbedded in shedder bar.
- Meter electronics shall be capable of direct MASS flow computation for saturated steam without external inputs.
- Meter provides one button autotuning for setting noise immunity circuits.
- Meter operating pressure/temperature range shall be (Vacuum to 2100 psig)/(-40°F to 500°F)
- Meter will be calibrated to/and provided with NIST calibration certificate.

CADILLAC® VORTEX METER MODEL NUMBER STRUCTURE

CV	Cadillac Vortex Flow Meter	CVC	Cadillac Vortex Converter
P	Piezoelectric pickup technology	P	Piezoelectric remote electronics
A	Size 0.5"	I	Indicator/Totalizer
B	Size 1"	U	Universal Mounting Bracket
C	Size 1.5"	XXFT	Interconnecting Cable
D	Size 2"	FM	FM Approvals
E	Size 3"		
F	Size 4"		
G	Size 6"		
H	Size 8"		
I	Size 10"		
J	Size 12" (Sizes larger than 12" please call Factory)		
S	Standard Electronics		
M	Mass Electronics with integral RTD		
II	Integral Converter with Indicator/Totalizer		
RC	Remote Converter		
W	Wafer Style Body Optional (1/2" thru 4" only)		
F	Flanged Body		
150	ANSI Class 150		
300	ANSI Class 300		
600	ANSI Class 600		
900	ANSI Class 900		
FM	FM Approvals		

MASS COMPENSATION

For compressible fluids, such as gases or superheated steam, an external pressure compensation input will be required for the MASS electronics. Internally programmed Ideal Gas and Steam lookup tables will be referenced for online MASS computations. Integral RTD in shedder bar and lookup tables are provided through the MASS option. Terminations for pressure sensor are available for compressible fluids in electronics housing. For saturated steam no external inputs are required.