

Cadillac[®] Vortex Meter

Central Station Steam Co.[®]

GENERAL INFORMATION

CV-U Series

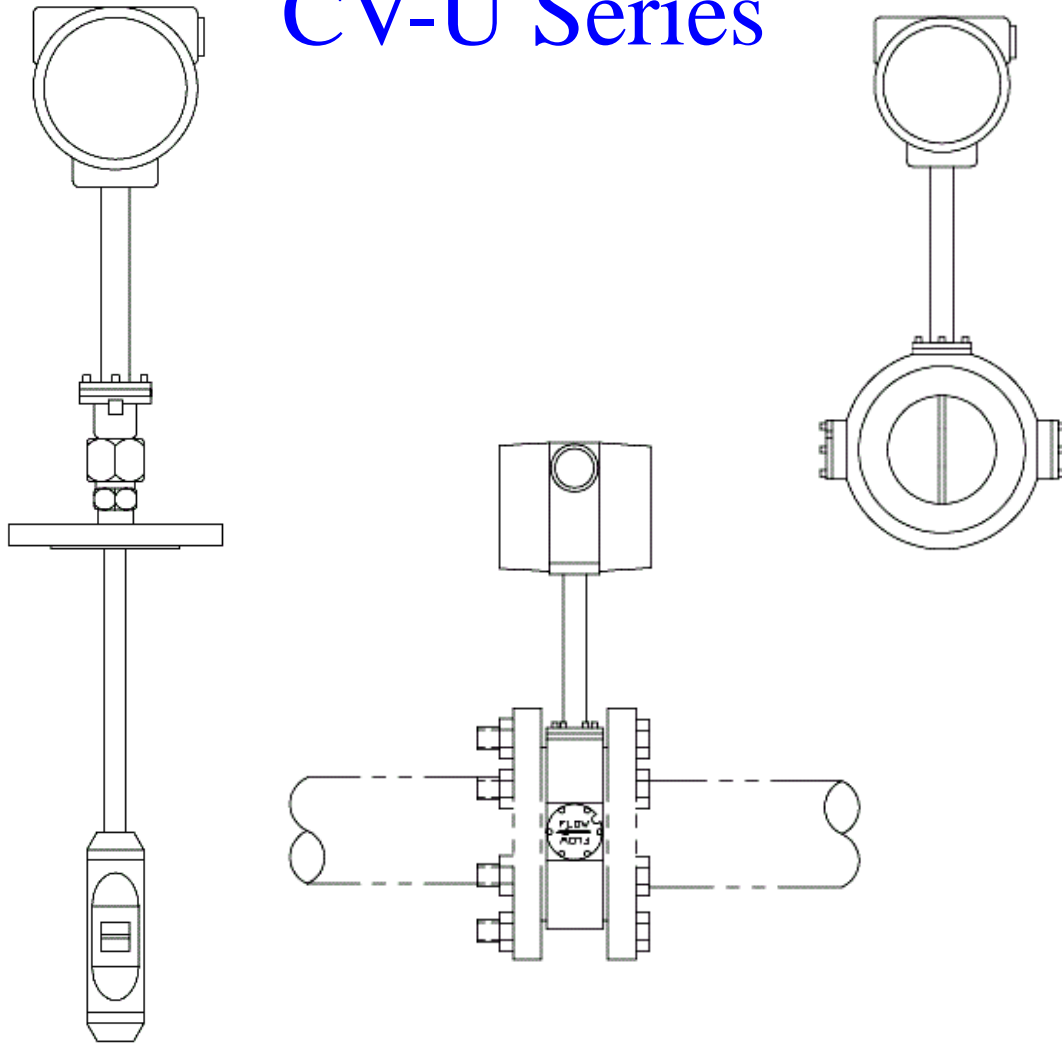

Central Station Steam Co.[®]

CADILLAC[®] METERS

15615 SW 74th Ave., Ste #150 Phone: 888-556-3913

Tigard, OR 97224

Fax: 503-624-6131

www.cadillacmeter.com

THE STEAM METER OF CHOICE

The Cadillac® Vortex Meter is a rate, totalizing, and Mass flow meter which is capable of measuring liquid, steam and gas. Due to its rugged design it is particularly suitable for direct steam measurement. In any steam system, the Cadillac® Vortex Meter is the number one technology choice due to Cadillac®'s accuracy, linearity, reliability and rangeability.

Like many other flow meters, the Cadillac® Vortex Meter is a velocity measuring device which computes flow by multiplying the effective cross sectional area of the flow meter with the detected fluid velocity. The meter has no moving parts and consists of a small vortex strut, embedded transmitting and receiving ultrasonic transducers, and amplifier assembly. It detects velocity by measuring the frequency of the vortices, as they peel off the vortex strut of the flowmeter. The frequency of these "Karman" vortices is directly proportional to the velocity of the moving fluid, whether this is a gas or liquid.

THE NEW INDUSTRY STANDARD

Since the late 1970's, the Vortex direct steam flow meters have been acknowledged as the industry standard. Customers choose the Cadillac® Vortex Meter because of proven:

- **ACCURACY, DEPENDABILITY, CONSISTENCY, LOW MAINTENANCE, RANGEABILITY.**

APPLICATIONS

- Data Source for energy management system, DCS, district-wide systems.
- Energy-Customer Billing from accurately totalized flow measurements.
- Basis for internal cost distribution using campus-wide systems.
- Process monitoring from central control rooms.
- Direct Steam measurements at both Boiler and point of use locations.
- Natural Gas measurements for Boiler fuel flow.

FEATURES

- **ACCURACY: +/-1.0% of the reading for liquids, gas and steam (Repeatability: 0.5% of reading) .**
High accuracy, linear throughout the entire dynamic measuring range. (See Flow Range table on next page)
- **RANGEABILITY: Typically 25 to 1 turndown or up to 35 to 1 if sized for "Best Fit".**
With seasonal steam load variation, the need for a large turndown is essential. Cadillac® Vortex Meters will accurately measure all load requirements with proper sizing.
- **LONGEVITY: Mean time between failure (MTBF) of 50 years.**
With no moving parts and through simple robust design the MTBF of the shedder bar is 50 years. With proper system maintenance Cadillac® Vortex Meters will provide reliable, accurate service beyond all flow technologies.
- **MODERN ELECTRONICS: Meeting the challenges of the next millennium**
Meters are equipped with electronics capable of mass flow computation for varying steam loads/pressure. Electronics will register locally, remotely or interface with an energy management system. Built to withstand the toughest conditions.

PRINCIPLE OF OPERATION

The "Karman" vortex meter principle is clearly illustrated by a flag waving in the wind. As the air passes across the flag pole, vortices peel off and the flag is shaped by these pressure areas. You will notice that, at low wind velocity, the flag will move slowly from side to side. As the wind increases, the flag will start to flutter and ripple, representing the increased frequency and intensity of these flag pole generated vortices as they pass. Wind velocity can thus be determined by measuring the frequency of that flutter.

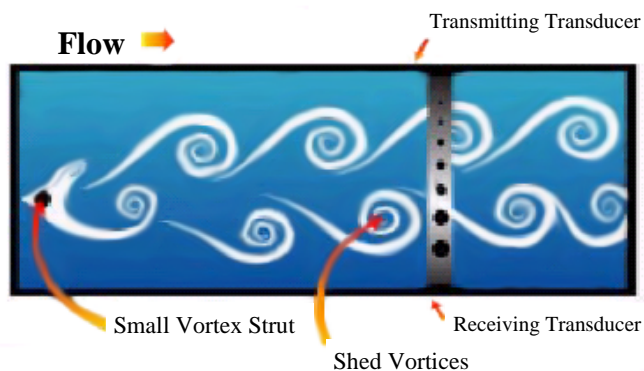

The small vortex strut of the Cadillac Vortex Meter sheds the vortices, which then pass through an ultrasonic beam, generated by flush mounted transducers (see illustration), where they are detected and counted. The frequency of these vortices is directly proportional to the fluid velocity and exact volumetric flow rate is computed knowing the internal cross sectional area. Each vortex meter is tested to determine the relationship between velocity/flow rate and vortex

(Continued on page 3)

(Continued from page 2)

frequency, which results in a meter K-factor expressed in "Pulses/Gallon". This volumetric relationship is then converted to relative engineering units, which the flow meter converter can then retransmit via a 4-20 mADC current signal or conditioned pulse. An optional LCD Indicator/Totalizer can display and totalize in engineering units of the users choice. For compressible mediums, such as gases and steam, the meter amplifier can correct for temperature and pressure with the MASS option, which includes a temperature element in shedder bar and look up tables for ideal gases and steam. For mediums other than saturated steam an external pressure source must be provided as shown in the drawing below. Outputs from the meter with the MASS option are compensated and linear for the compressible medium being measured.

METER INSTALLATION

To ensure optimum performance and operation, Vortex meters should be sized to operate near or at the higher end of the operating range. This is due to the finite low end ability of the meter to generate and measure vortices. This is typically referred to as low flow cutoff. With other technologies on the market this low flow cutoff value is relatively high, thus requiring piping reductions as illustrated to bring the meter within a reasonable range for operation. In a typical steam heating system this is typically 1-2 pipe diameters.

However, with the Cadillac® Ultra-sonic Vortex technology, sensitivity is dramatically increased, which results in a significant reduction in low flow cutoff values. Resulting in line size meters and the cost savings of not having to manufacture reducing spool pieces.

METER SIZING INFORMATION

The low-end performance of the meter is a function of the fluid's ability to generate a vortex, which using ultrasonic technology is at the very threshold of when vortices for a given fluid are shed. This threshold is dependent on fluid velocity, density and Reynolds number. The high end of the flow meter is amplitude limited, which ultimately impacts the electronics ability to distinguish one vortex from another. In most cases, this represents 125 ft/sec for gases and 20 ft/sec for liquids. To guarantee satisfactory performance, we will check every vortex meter application for suitability and will require process medium, pressure, temperature and expected minimum and maximum flow rates. For easy reference, we are providing you with a table (see below) for saturated steam at various pressures. The tables list the minimum and maximum flow capability, between which a flow measurement can be made at stated accuracy. Outside those limits, the accuracy will deteriorate somewhat, the extent of which will depend on the quality of the installation.

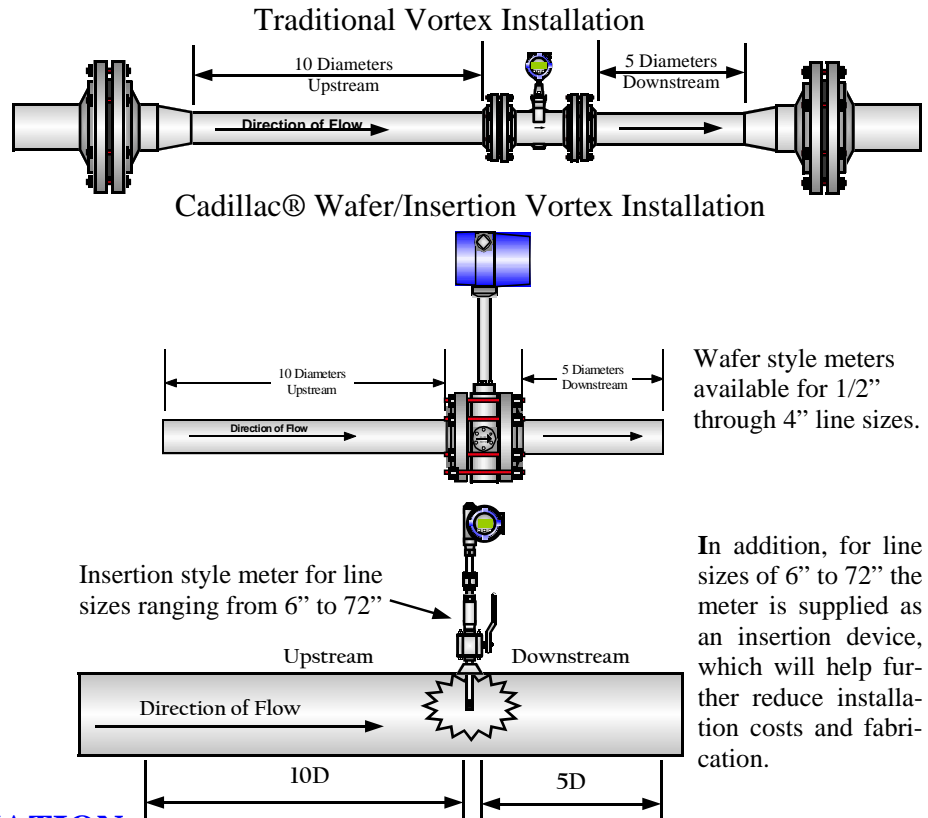

Saturated Steam Flow Range Table. (Steam Flow in lbs/hr)

Pipe/Meter Size	10 PSIG	20 PSIG	40 PSIG	60 PSIG	80 PSIG	100 PSIG	120 PSIG
0.5"	2-36	2-50	3-76	4-102	5-128	6-154	7-179
1.0"	5-127	6-175	10-268	13-359	16-450	19-540	23-628
1.5"	11-363	15-500	23-766	31-1027	39-1285	39-1542	54-1796
2.0"	15-581	25-800	38-1226	51-1644	64-2057	77-2467	90-2875
3.0"	47-1163	65-1600	100-2452	134-3288	167-4114	154-4934	234-5749
4.0"	84-1745	115-2400	176-3678	236-4932	295-6172	308-7400	414-8624
6.0"	214-5353	300-7364	451-14295	605-19166	757-26509	839-31785	1059-37043
8.0"	360-9517	523-13092	802-25415	1076-34074	1347-47128	1491-56507	1882-65854
10"	595-14870	818-20456	1254-39709	1681-53240	2104-73637	2329-88292	2940-102897
12"	857-21413	1178-29457	1806-57181	2421-76666	3030-106038	3354-127140	4233-148172

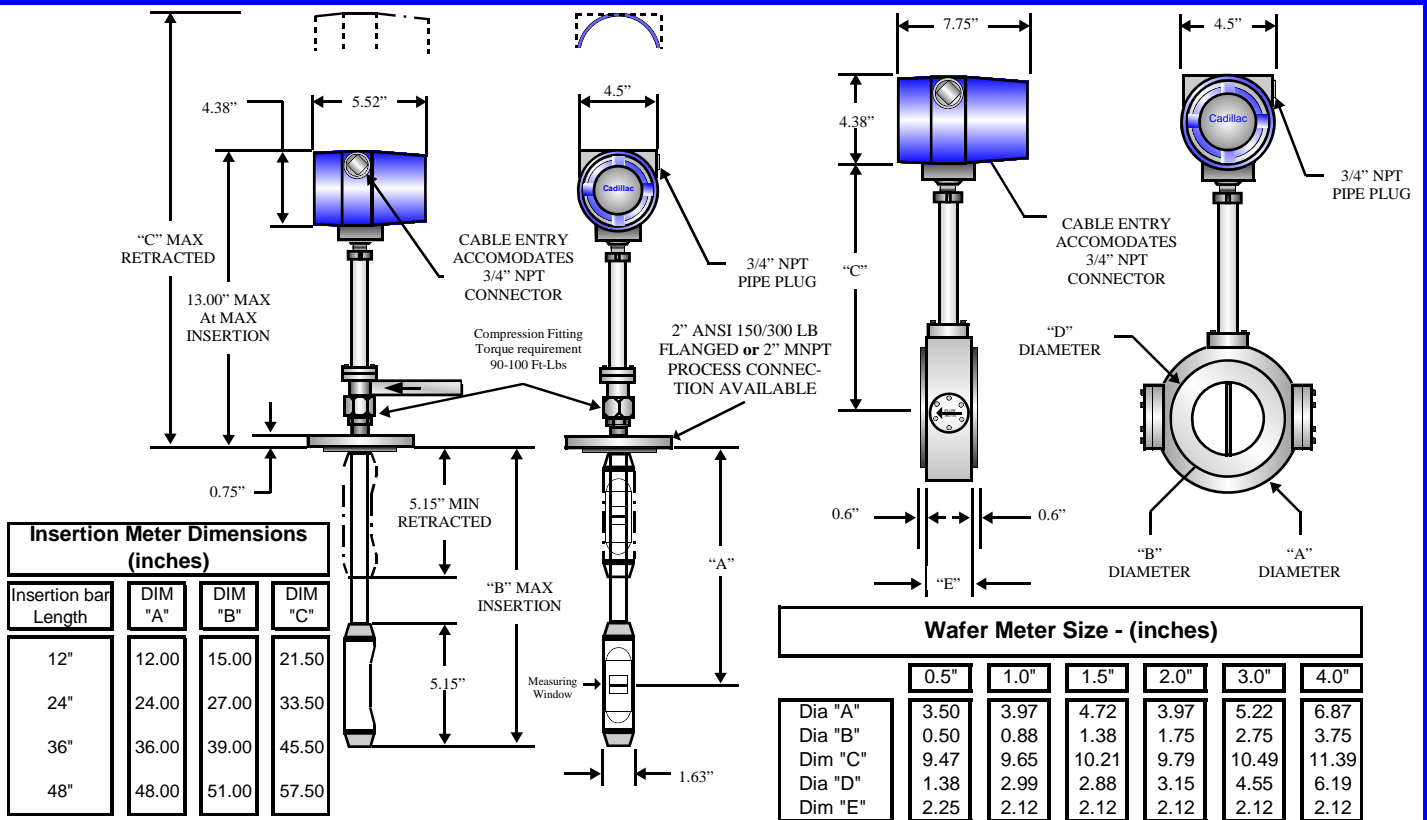

CADILLAC® VORTEX METER GENERAL SPECIFICATIONS

- Meter will consist of an in-line or insertion type flow meter assembly with remote or integral electronics.
- Meter available with local or remote indication or blind housings.
- Meter available with analog (4-20 mADC) output.
- Meter will have typical turndown of 25:1, or up to 35:1 if sized for "Best Fit".
- Meter will have an accuracy of $\pm 1.0\%$ of reading across entire operating range.
- Instantaneous and totalized flow available at local indicator or remotely through output.
- Meter measures flow using the Karman vortex shedding principle.
- Vortices shall be detected with an ultrasonic receiver.
- Meter electronics shall be capable of direct mass flow computation for saturated steam without external inputs.
- Input power shall be 15-48 VDC, analog output shall be 4-20 mADC, 2-Wire.
- Operating pressure/temperature of meter shall be (-5 to 140 psig)/(-20° to 360°F)
- Meter will be calibrated to/and provided with NIST calibration certificate.

CADILLAC® VORTEX METER MODEL NUMBER STRUCTURE

CV	Cadillac Vortex Flow Meter
U	Ultrasonic pickup technology
A	Size 0.5"
B	Size 1"
C	Size 1.5"
D	Size 2"
E	Size 3"
F	Size 4"
G	Size 6"
H	Size 8"
I	Size 10"
J	Size 12" (Note: For larger line sizes consult factory)
S	Standard Electronics
M	Mass Electronics with integral RTD
II	Integral Converter with Indicator/Totalizer
IN	Integral Converter - Blind
RC	Remote Converter
W	Wafer Style Body (1/2" thru 4" only)
I	Insertion Style (6" to 72")
150	ANSI Class 150
300	ANSI Class 300
FM	FM Approvals

CVC	Cadillac Vortex Converter
U	Ultrasonic remote electronics
I	Indicator/Totalizer
N	Blind
U	Universal Mounting Bracket
XXFT	Interconnecting Cable*
FM	FM Approvals

** Maximum cable length between electronics and flow tube is 50 feet.

MASS COMPENSATION OPTION

For compressible fluids, such as gases, an external pressure compensation input will be required for the MASS electronics. Internally programmed Ideal Gas and Steam lookup tables will be referenced for online MASS computations. Integral RTD in shedder bar and lookup tables are provided through the MASS option. Terminations for pressure sensor are available for compressible fluids in electronics housing. For saturated steam no external inputs are required.